

Kitchen & Bath Planning Guidelines

With Support Spaces and Accessibility

Fourth Edition



Kitchen & Bath Planning Guidelines

With Support Spaces and Accessibility

Fourth Edition

Summary:

The new Kitchen & Bath Planning Guidelines with Support Space and Accessibility, 4th ed. has influenced the judging criteria for future NKBA Design Competition. With hundreds of guidelines spread across multiple interior rooms and zones, the following is a summary of the health, safety, and welfare requirements recommended that submissions be assessed upon.

Definition:

User: The primary or secondary users of the household. Tertiary users are considered guests.

Fixture: A plumbing fixture such as a sink or faucet, toilet, bidet, integrated toilet/bidet, bathtub, etc.

Equipment: Equipment used for food cooking, food baking, food warming, food preservation, food freezing, dish washing or clothes washing.

Refer to the following **MINIMUM** guidelines applied to all kitchens, baths, and support spaces when submitting your entry

1.1 Doorways

The clear opening of a single doorway should be a minimum of 34" (865 mm) wide, requiring a 36" (915 mm) wide door leaf. The clear opening of a doorway with multiple leaves should be a minimum of 48" (1 220 mm) wide. All doorways should be a minimum of 78" (1 980 mm) high. The ceiling height over a doorway should be a minimum of 80" (2 030 mm).

- Doors should not require excessive effort or special knowledge to open.
- Doors with full glazing should have lightly tinted, tempered glass with a visible pattern, mullions or markings at the user's eye level for increased safety.
- Doors with partial glazing, the lock rail or mid-rail should be at a maximum of 36" (915 mm) Above Finished Floor (AFF) to the bottom of the glazing to accommodate line of sight for users of varied heights, ages, and mobility. Glazing must be tempered or approved equal material.
- Maneuvering with a wheelchair/mobility-aid at the **pull**-side of a doorway, provide a clear floor space that is the doorway width plus 24" (610 mm) wide and 60" (1 525 mm) deep.
- Maneuvering with a wheelchair/mobility-aid at the **push**-side of a doorway, provide a clear floor space that is the doorway width plus 12" (305 mm) wide by 48" (1 220 mm) to 52" (1 320 mm) deep.

Sliding and/or pocket doors should have the same clear opening provisions. A doorway with an optional off-set hinge should provide the minimum clear opening.

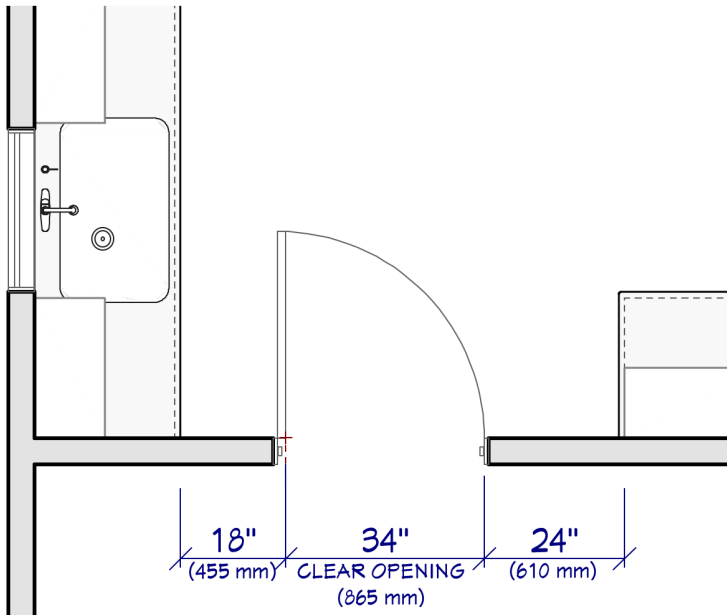

Figure 1.1.a Doorway Clearance

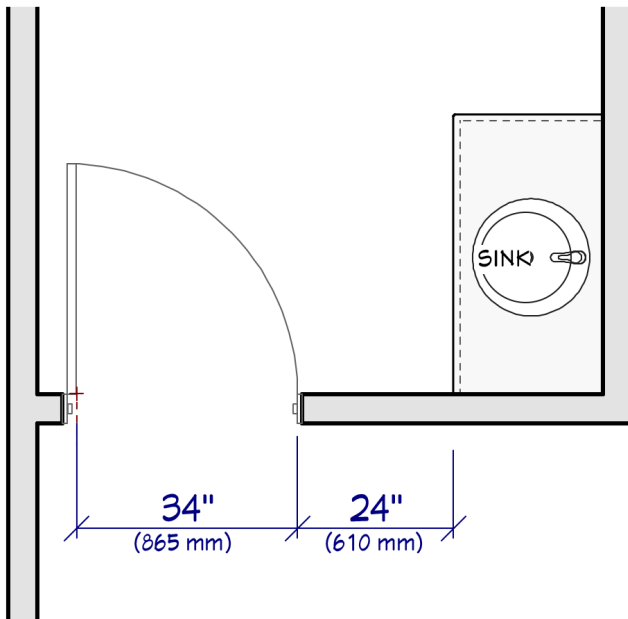

Figure 1.1.b Doorway Clearance

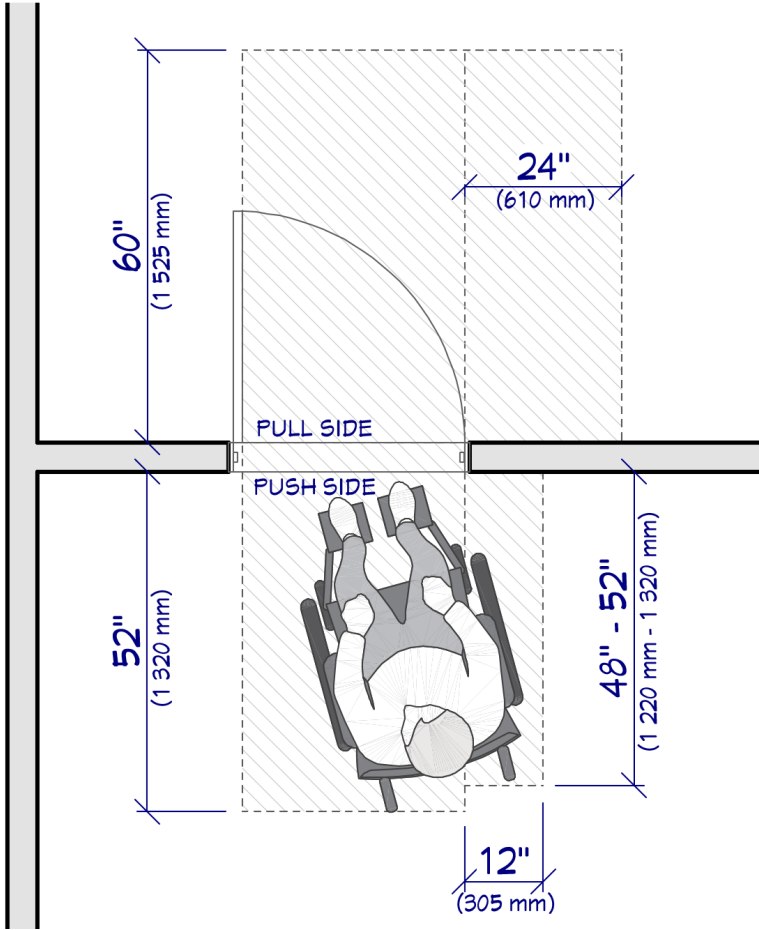

Figure 1.1.c Maneuvering Clearances at Doorways

1.3 Floor Transitions

A floor transition is a material and/or height change from one (1) space or area to another.

- Transitions between material floor surfaces should be flush.
- When flooring transitions vary in height between surfaces or doorways, the transition should be: a) eased and no higher than 1/4" (6 mm), or b) beveled and no higher than 1/2" (13 mm).
- Where a step exists between floor levels, the minimum height should be no less than 4-3/4" (120 mm) and no higher than 7-3/4" (196 mm). Multiple steps between floor levels are regulated by the applicable jurisdiction.

Where handrails are required between floor transitions, they should be installed at a minimum of 36" (915 mm) AFF or other requirements as determined by the jurisdiction.

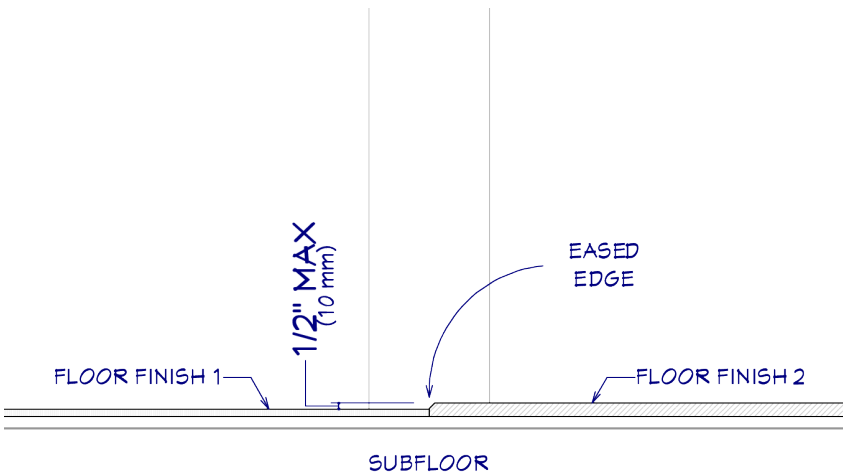

Figure 1.3.a Eased Floor Transitions

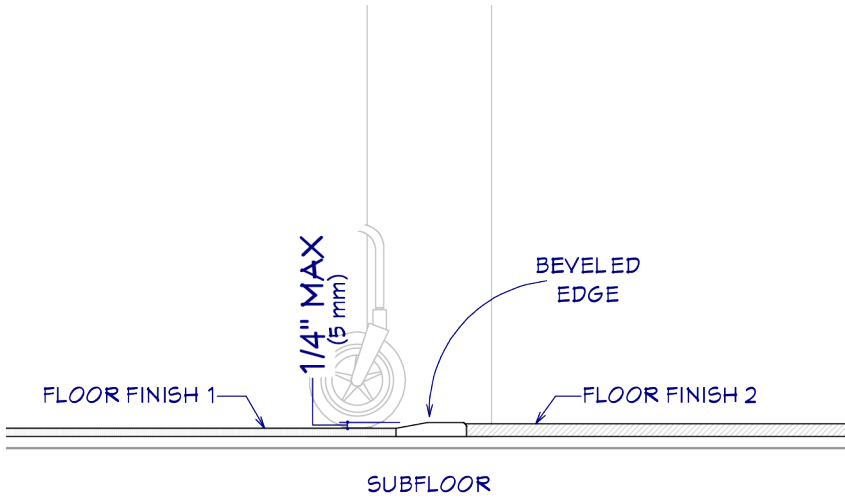

Figure 1.3.b Beveled Edge Floor Transitions

1.4 Door & Equipment Interference

Entry and exit doors, cabinet doors/drawers and equipment doors swings should be planned in consideration of the door and floor clearance needed and path of travel of the user.

- Fixtures, equipment doors, cabinet doors and cabinet drawers should not obstruct the operation of any door.
- For 2 × 4 (NOM) or 2 × 6 (NOM) wall assemblies, sliding and/or pocket door framing and door leaves should avoid obstructions or interference with in-wall electrical receptacles or other plumbing supply and rough-in locations.
- No equipment doors should operate in conflict with each other.
- No door or drawer, including equipment doors, should collide with any adjacent work surface or obstacle, such as a cabinet, casework or decorative hardware.

The swing direction of door leaves should consider the user's standing location, hand position and appropriate clearances to avoid injury.

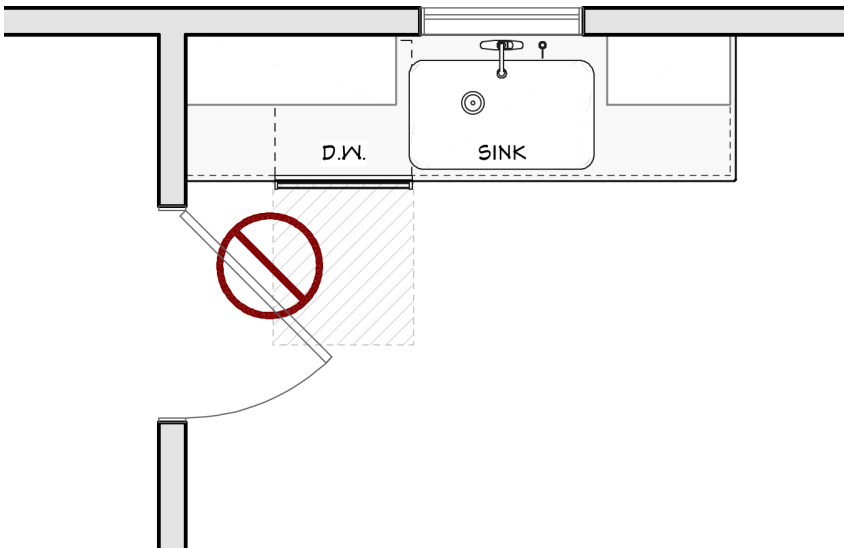

Figure 1.4.a Door & Equipment Interference

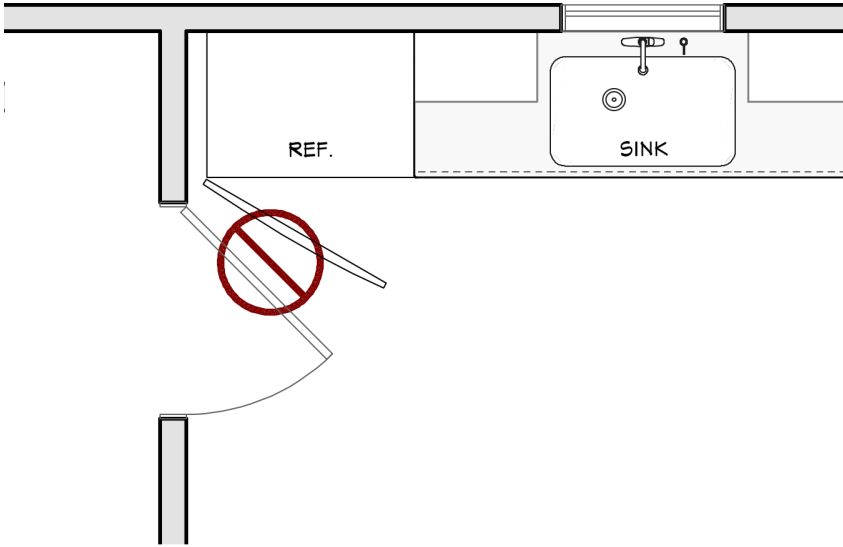

Figure 1.4.b Door & Equipment Interference

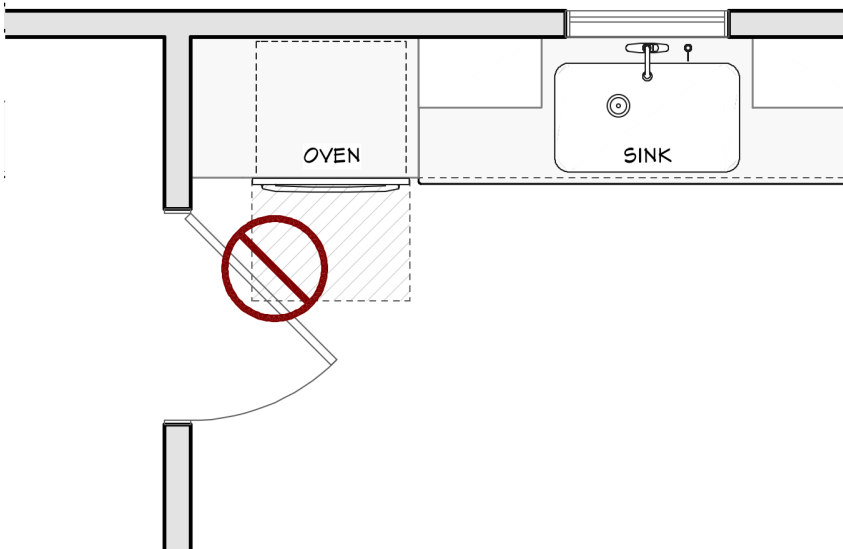

Figure 1.4.c Door & Equipment Interference

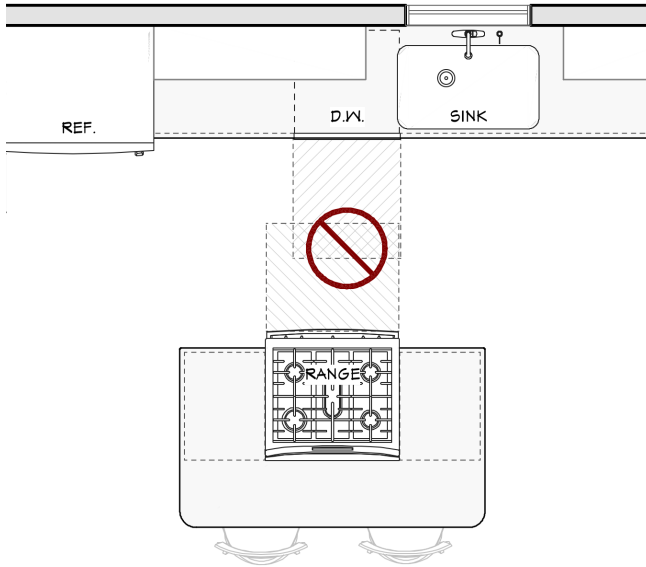

Figure 1.4.d Door & Equipment Interference

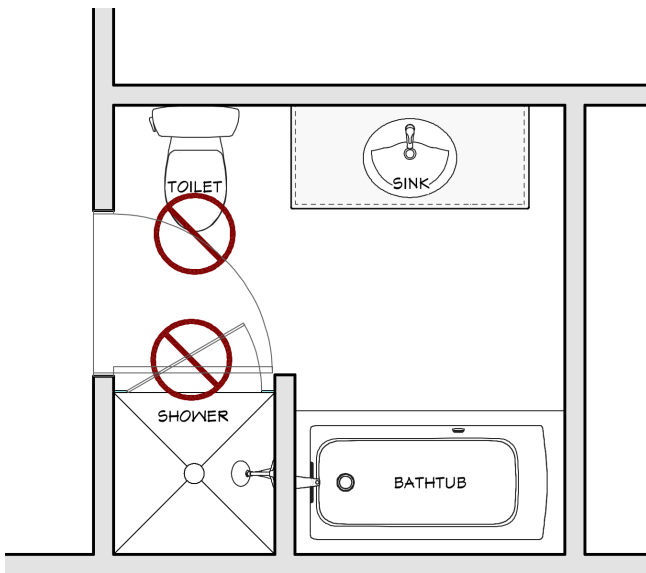

Figure 1.4.e Door & Equipment Interference

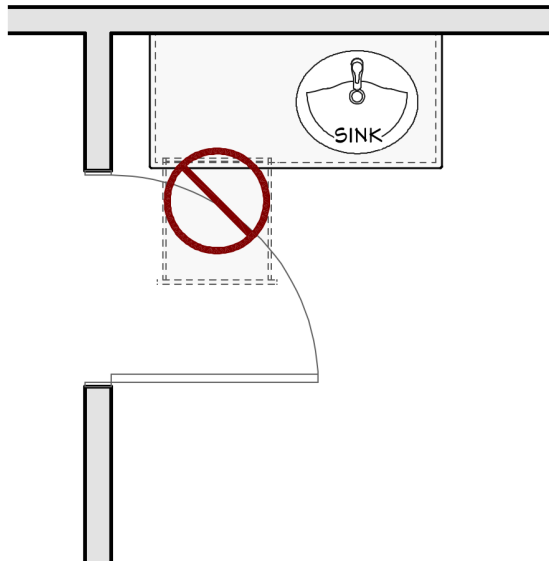

Figure 1.4.f Door & Equipment Interference

1.5 Clear Floor Space at Activity Centers

Clear floor space provides a minimum physical, clear and unobstructed space at each planned activity center, fixture, and equipment for approach and use by a variety of users. Clear floor space may be planned for a forward or side approach, depending on the planning arrangement of the other activity centers and the six (6) physical variables of users.

Clear floor space for each activity center may overlap; however, Clear floor space may not be obstructed by a door leaf.

- A minimum clear floor space of 30" (760 mm) to 32" (815 mm) by 48" (1 220 mm) to 52" (1 320 mm) should be provided at all activity centers.
- The clear floor spaces should be center-lined with the fixture or equipment and may overlap with other clear floor space(s) at activity centers.
- The clear floor space should not be obstructed by door swings, cabinetry, casework, fixtures or equipment.

The planning of the clear floor space for a wheelchair/mobility-aid may be perpendicular for a forward approach (preferred) or parallel to the center of the activity center for a side approach.

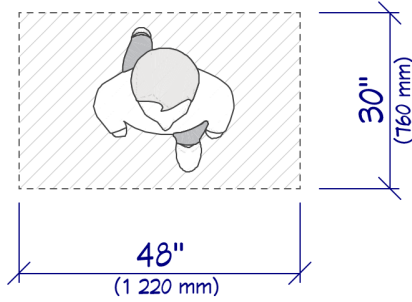

Figure 1.5.a Clear Floor Space at Activity Centers

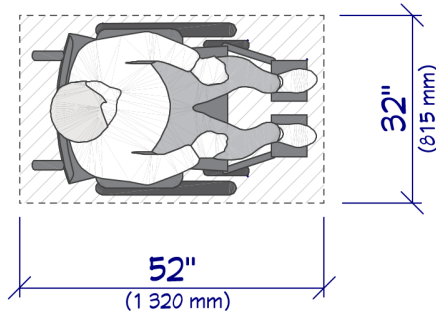

Figure 1.5.b Clear Floor Space at Activity Centers

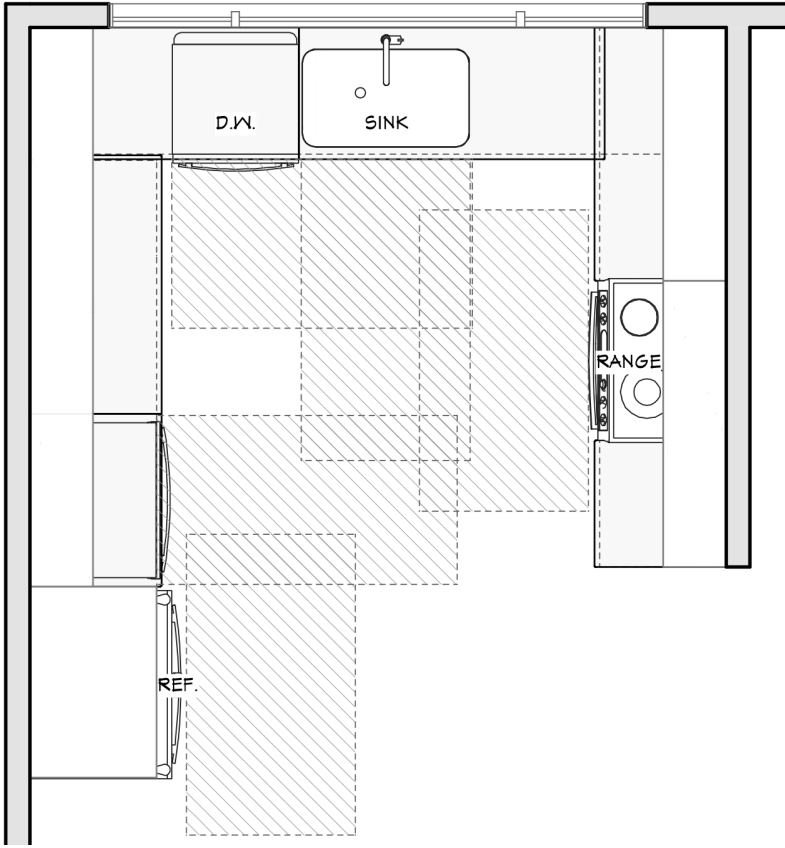

Figure 1.5.c Overlapping Clear Floor Space at Kitchen Activity Centers

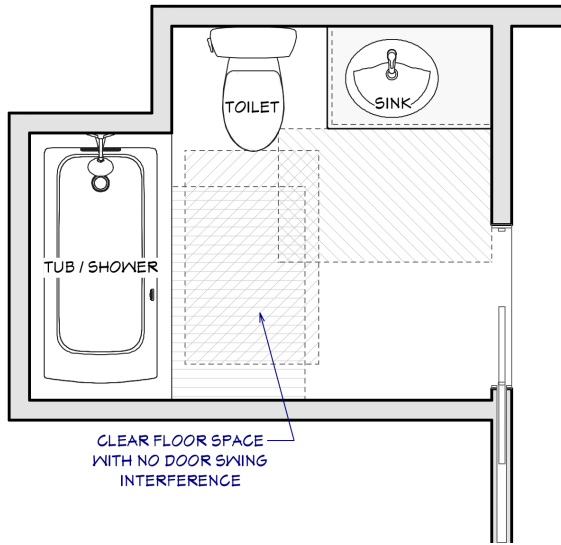

Figure 1.5.d Overlapping Clear Floor Space at Bath Activity Centers

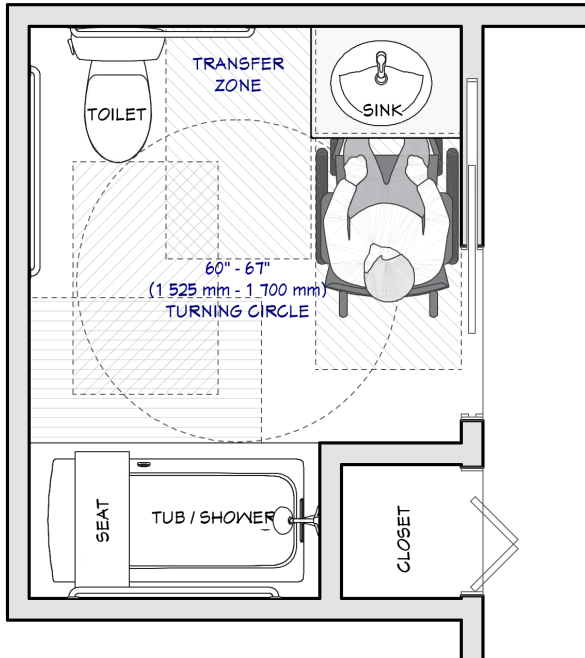

Figure 1.5.e Overlapping Clear Floor Space at Bath Activity Centers

1.6 Work Zone Clearances at Activity Centers

Work zone clearance at an activity center is an unobstructed area occupied by the user to perform tasks. It includes a work route and clear floor space to maneuver in the space. Clearances at activity centers do not include passageways.

- Work zone clearance at activity centers should be between 48" (1 220 mm) to 52" (1 320 mm) wide.
- To accommodate a wheelchair/mobility-aid, provide a 60" (1 525 mm) to 67" (1 700 mm) wide clearance for a turning circle or to pass-by.
- An optional T-Turn may be provided at work zones (see A.3 Common Accessible Design Requirements on page 244: Figure A.3.f).
- To accommodate a wheelchair/mobility-aid, an additional buffer space of 8" (200 mm) to 10" (255 mm) wide should be provided when an activity center is planned directly adjacent to a wall or other obstacle (for example, sink area.)

Work zone clearances at activity centers should be measured from the edge of each obstacle, work surface edge, and/or equipment handle. Larger mobility aids may have additional requirements for work zone clearances at activity centers. Work zone clearances at activity centers may overlap clear floor space. Approach and access requirements are listed and illustrated in each activity center.

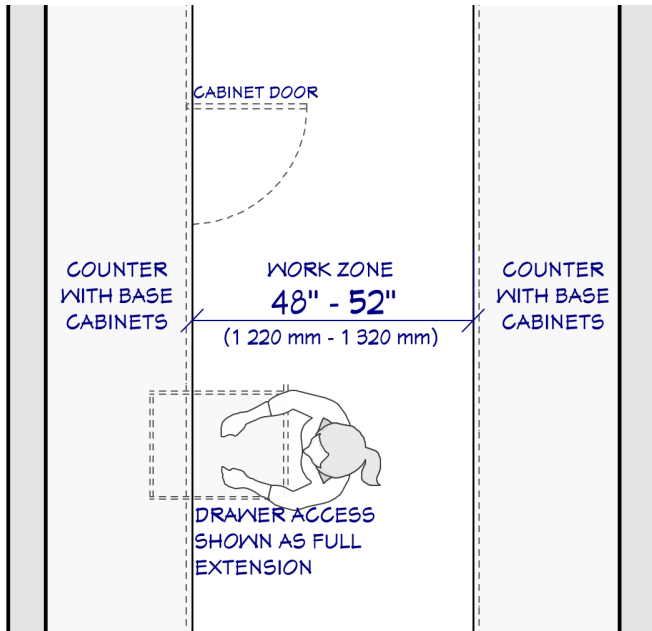

Figure 1.6.a Work Zone Clearances at Activity Centers

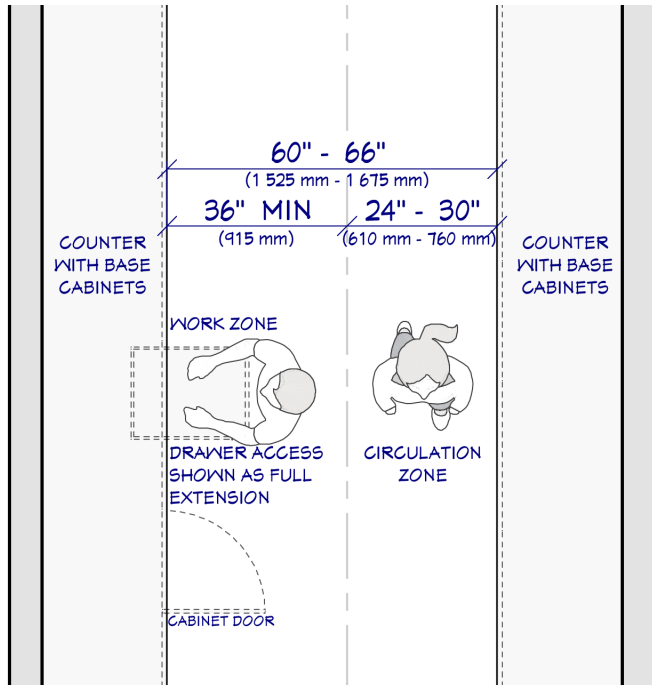

Figure 1.6.b Work Zone Clearances at Activity Centers

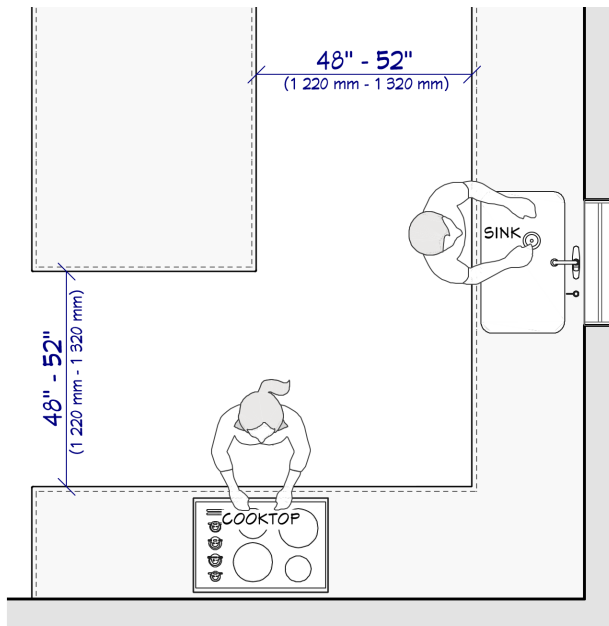

Figure 1.6.c Work Zone Clearances at Activity Centers

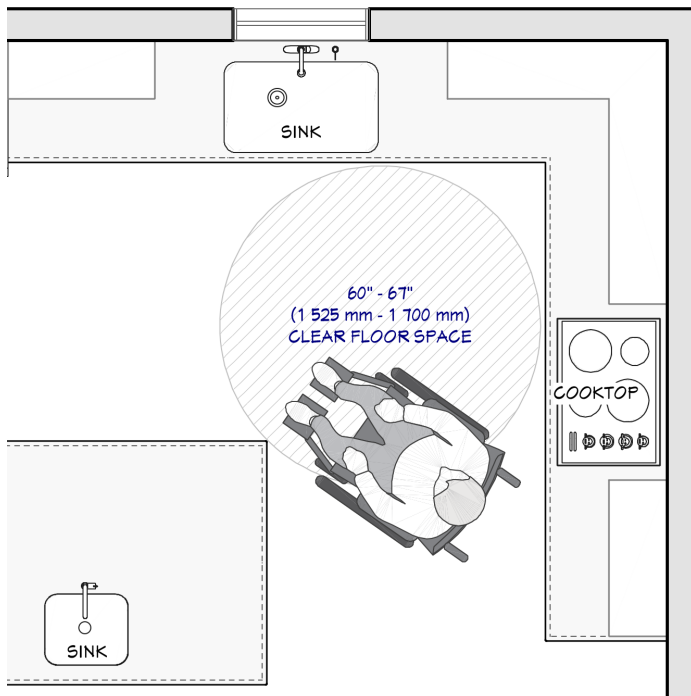

Figure 1.6.d Work Zone Clearances at Activity Centers

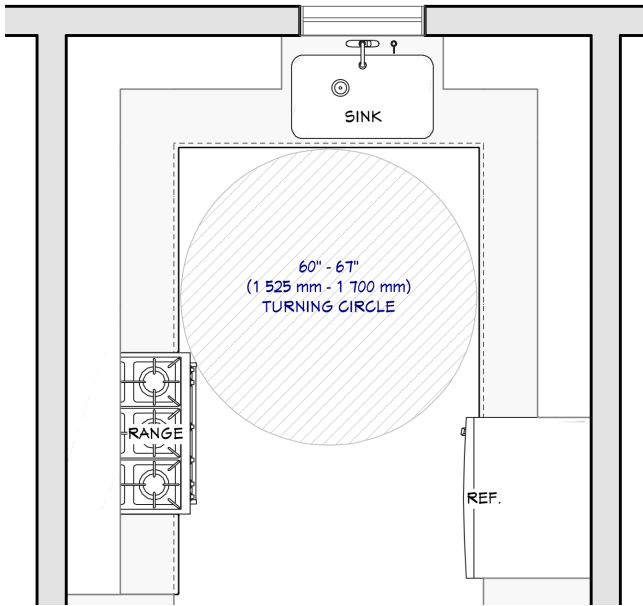

Figure 1.6.e Work Zone Clearances at Activity Centers

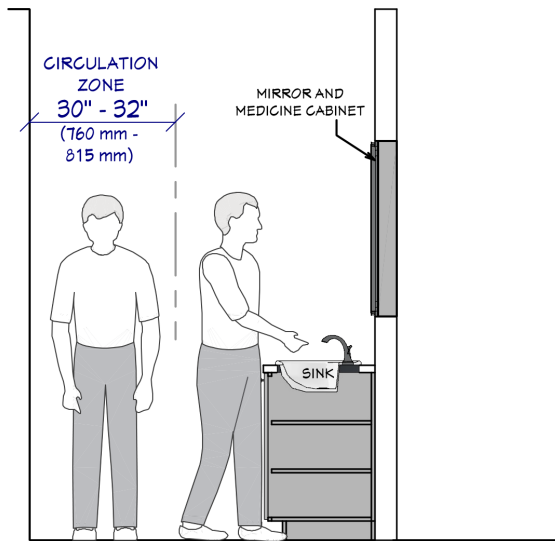

Figure 1.6.f Work Zone Clearances at Activity Centers

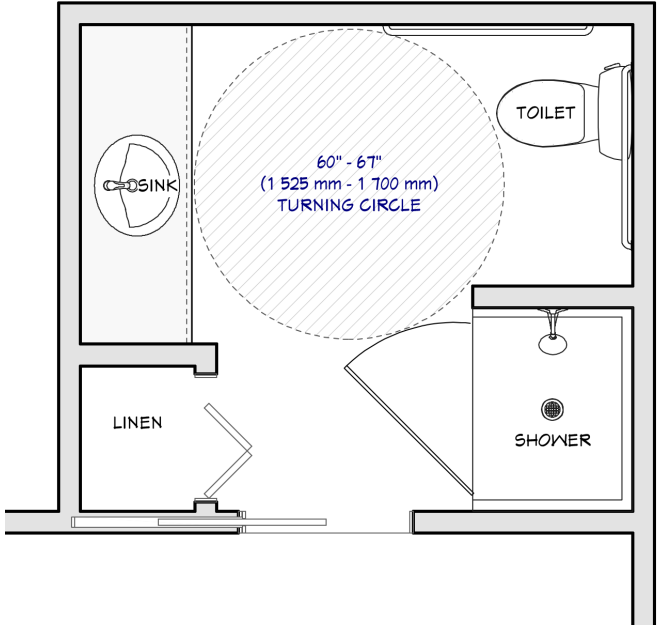

Figure 1.6.g Work Zone Clearances at Activity Centers

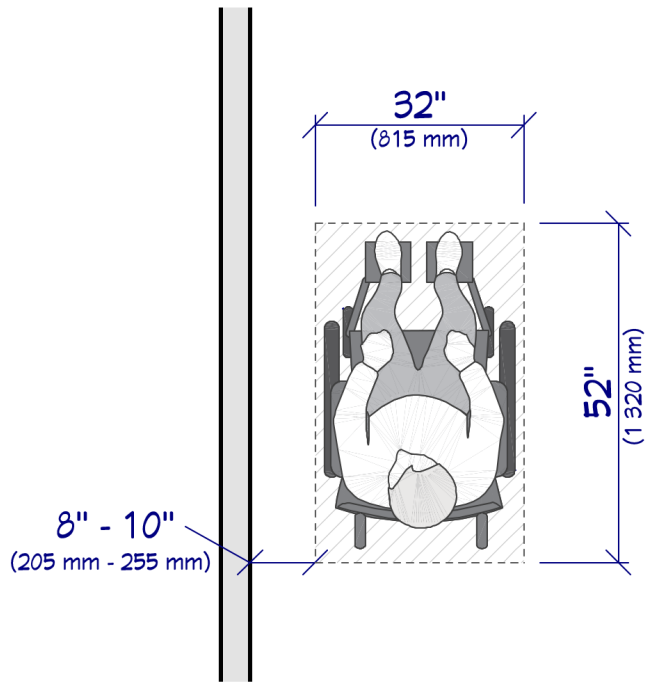

Figure 1.6.h Work Zone Clearances at Activity Centers

1.7 Passageways

A passageway is a minimum 36" (915 mm) wide unobstructed clear floor area with a minimum ceiling height of 80" (2 030 mm) that is not planned within a circulation zone at activity centers.

- No obstacle should project into the passageway by more than 4" (100 mm).
- Passageways that accommodate a wheelchair/mobility-aid, should provide a 60" (1 525 mm) to 67" (1 700 mm) turning circle at all changes in travel direction.
- For passageways where a turning circle is not possible for a change in travel or direction, provide an unobstructed clear floor area for a T-turn (see Figure A.3.f Toe and Knee Clearance for Wheelchair Users on page 246).
- Where two users with wheelchair/mobility-aid pass-by each other, provide an unobstructed clear floor area of 60" (1 525 mm) to 67" (1 700 mm) wide.

Passageways may be increased in width to accommodate the depth of obstacles, such as molding or millwork, or other safe passage as required by all users.

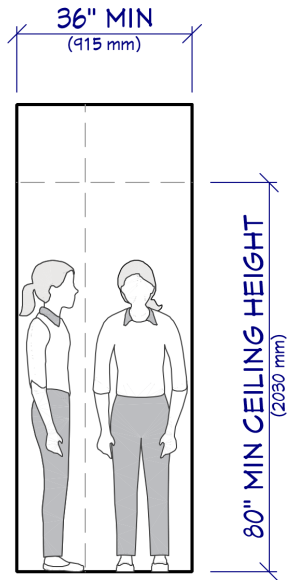

Figure 1.7.a Passageways

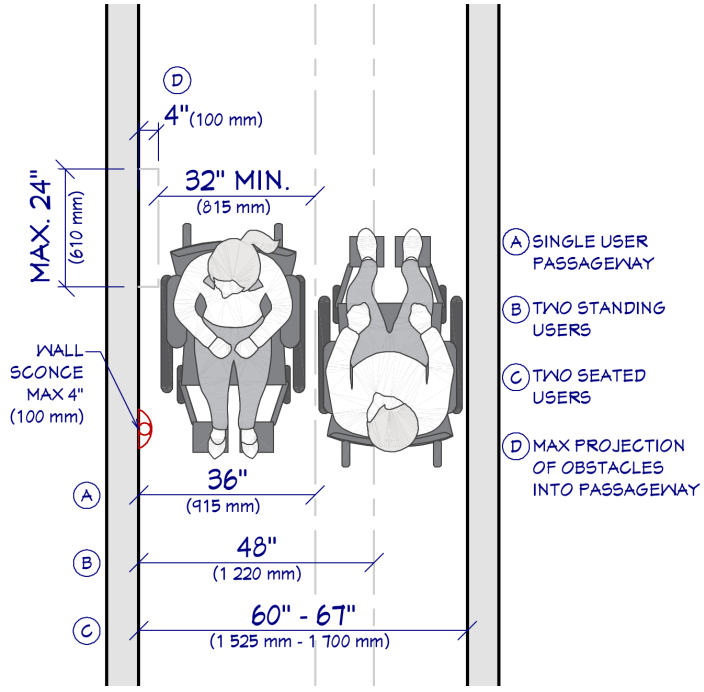

Figure 1.7.b Passageways

4.1 Cabinetry & Casework Planning

Cabinetry and casework production standards vary by stock, semi-custom, and custom manufacturing as determined by the Architectural Woodworking Institute (AWS) or the Architectural Woodworking Manufacturers Association of Canada (AWMAC). Cabinet casework, doors, drawers, decorative hardware and functional accessories should be planned in consideration for the access of a variety of users.

- All cabinet interior accessories (base, wall and tall) should be fully accessible and should consider the height and range of motion of the user.
- When a corner cabinet is planned, components allowing full access to the interior should be used.
- Door swings with 165° hinges for base cabinets should be utilized and planned in consideration of the seated user.
- Sliding doors (bi-pass doors) should be used when the cabinet door swings interfere with the safe operation of other casework and fixtures.
- Drawers should not require excessive force to open and provide full access to the drawer box.
- Cabinet drawers should not be planned within the swing of any door leaf.
- Cabinet decorative hardware should reduce excessive twisting of the wrist and not require a tight grasp.
- Cabinet decorative hardware should not interfere with the safe operation of other cabinet doors, cabinet drawers, equipment, fixtures and other installed casework.
- Wall-hung (floating) cabinets require a combination of wall-blocking and/or wall mounted brackets or other mechanisms to support the combined load of the cabinetry, countertop, fixtures and weight of the activity performed by the user.
- Cabinetry with glass inserts: the glazing must be tempered or approved equal.

When cabinetry and casework are installed in interior spaces, appropriate year-round humidity and environmental controls should be provided to maintain optimum performance of installed products. All installed components should consider the manufacturing quality, performance, cleanliness, maintenance and life-cycle of the product.



Figure 4.1.a Cabinetry & Casework Planning



Figure 4.1.b Cabinetry & Casework Planning

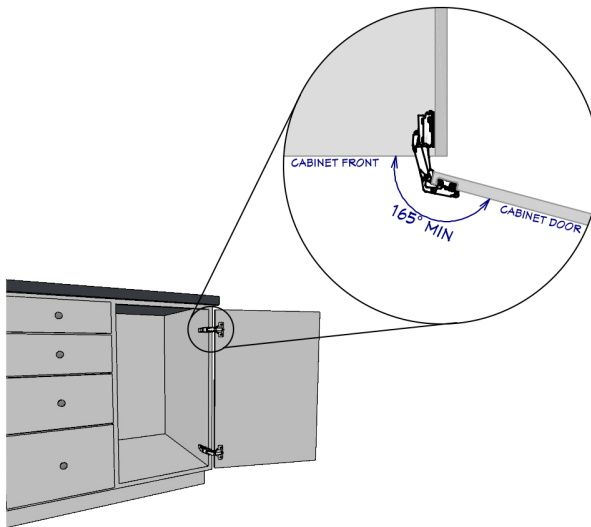

Figure 4.1.c Cabinetry & Casework Planning

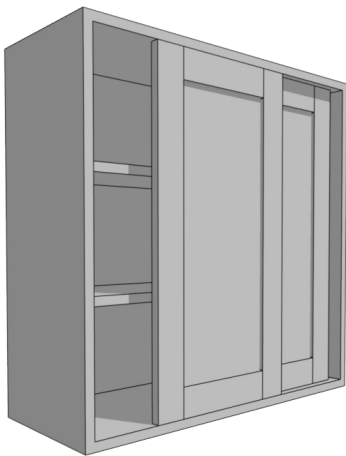

Figure 4.1.d Cabinetry & Casework Planning

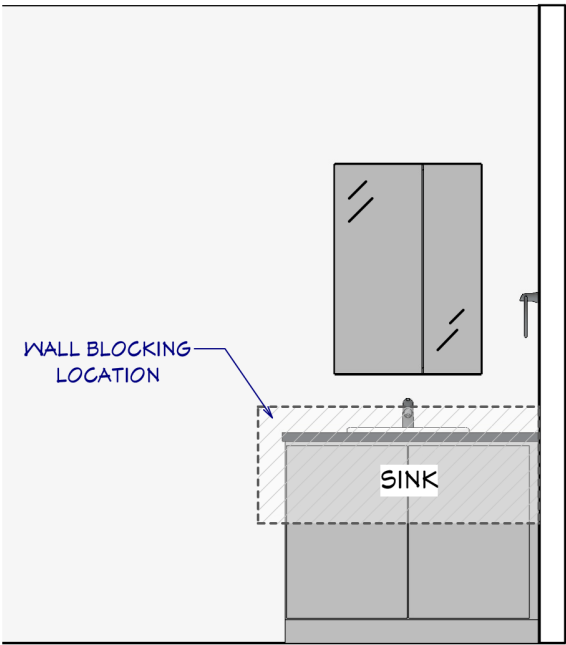

Figure 4.1.e Cabinetry & Casework Planning

4.2 Glazing, Windows & Glass Partitions

Glazing for interior bath/shower or other partitions should be lead-free and treated with anti-fog and antimicrobial coatings when available (see 3.3.8 Bathtub/Shower Glazing, Doors, and Curtains on page 148).

- ❑ Natural lighting sources (windows, skylights and/or solar tubes) should be incorporated into the space wherever possible.
- ❑ To add or eliminate windows and exterior doors, glazing calculations may be required depending on the jurisdiction.
- ❑ When a window is planned over a cooking surface, the window should not be operable or have any window treatments affixed within the combustible area (see 2.2.4 Cooking Surface Equipment Planning on page 58).
- ❑ Any glazing (window or doors) whose bottom edge is less than 18" (460 mm) AFF or less than 60" (1 525 mm) AFF and in and/or adjacent to a tub/shower fixture, the glazing must be tempered, safety or approved equal.
- ❑ Windows should be operable and when modesty is required, provide an appropriate privacy glass.

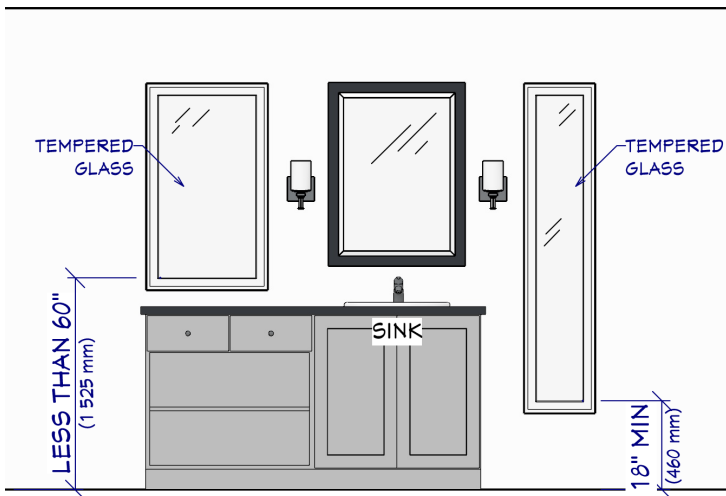

Figure 4.2.a Cabinetry & Casework Planning

Manufacturers may provide more specific NRC ratings of materials and finishes. Zoning of interior spaces with staggered doorways, halls, and separation from common walls, etc., to avoid a straight-line path to noise will improve acoustical control. An acoustical consultant may be employed in order to address the considerations of the users.

4.4 Material & Finish Planning

Interior finishing material selections and installation in a space may vary. Considerations include safe product handling, maintenance of finishes, Indoor Air Quality (IAQ), life-cycle costs, wellness and safety of the users.

- The use of products, materials, and finishes, including furnishings, containing Volatile Organic Compounds (VOCs) should be avoided.
- The contrast in color, surface texture, finish, and reflectance qualities of materials may improve visibility and point-of-use activities for a variety of users.
- The specification of slip-resistant flooring surfaces and radius work surface edges and corners will prevent injury.
- Horizontal work surfaces should be hygienic and food-safe, bacteria and stain-resistant.
- Materials installed on vertical surfaces should be bacteria and stain-resistant while considering the activity; such as water resistance at sinks and faucets, waterproofing in wet areas, and heat resistance at cooking surfaces.
- Supplemental heat sources (heat lamps, toe-kick heaters, radiant floor, wall-mount heaters) should consider the user's ideal human comfort zone.
- Sound transmission and acoustical privacy between adjacent spaces and in open-plan arrangements should be considered for the hearing abilities of all users.

Products containing all materials hazardous to users and materials containing VOCs may not be identified by a manufacturer. Third party authorities such as the Environmental Protection Agency, Health Canada, the World Health Organization, and Kitchen Cabinet Manufacturers Association provide testing data and regulatory requirements on indoor air quality and material safety. These authorities should be consulted prior to the selection, purchase, and installation of all materials in interior environments.

4.5 Human Comfort Zone

Heating and cooling systems are installed in dwelling units to provide a comfortable environment for occupants. The factors that effect of comfort on a body varies from person to person in the following ways:

- Warmer temperature due to age, circulation, or other health conditions.
- Sedentary lower body temperatures versus active higher body temperatures.
- Humidity, indoor air circulation, and solar/heat gain.

In addition to the guidelines (see 8.1 Ventilation Planning on page 218), the following may apply temperature and humidity controls:

Table 4.5.a	Human Comfort Zones	
	Comfortable Range	Tolerable Range
Air temperature	69°F to 80°F (21°C to 27°C)	60°F to 85°F (16°C to 29°C)
Relative Humidity (RH)	30% to 65%	20% to 70%
Air movement	50 ft/min to 200 ft/min (0.25 m/s to 1.02 m/s)	
Radiation	Body heat loss -> 85°F (29°C) -> Body heat gain	

8.1 Ventilation Planning

Ventilation provides humidity and fresh air control in a space and improves Indoor Air Quality (IAQ) by removing indoor air contaminants (cooking smoke, grease, excess humidity, dust, and so on.). All ventilation equipment should be provided for all spaces and exhausted to the exterior of the building envelope (see A.5 Ventilation Calculations for Baths on page 255).

The factors that contribute to the efficacy of ventilation and the removal of indoor air contaminants are:

- Size of the room
- Increased ceiling heights
- Number of and size of fixtures
- Number of users
- Type of fuel (gas or electric) used for the cooking surface
- Installation of ventilation equipment: size, exhaust rating and ducting requirements
- Make-up air requirements: location and installation
- Number of operable windows in the room or area

General Ventilation Planning

- Planning considerations include site and structural limitations, other equipment locations and casework placement.
- Ventilation equipment should be accessible for maintenance.
- Recirculating ventilation (duct-free) equipment or the elimination of ventilation equipment should be avoided.
- Flush mounted ceiling ventilation systems may have specialized requirements due to mounting heights and structural limitations.

- In some jurisdictions higher air exchange systems require a make-up air system to return fresh air into the room at a rate equal to the air exhausted.
- Location and installation requirements of a make-up system should be determined by an HVAC specialist prior to final design solution.

Kitchen Ventilation Planning

- Ventilation equipment should be provided for all cooking surfaces (see 2.2.5 Ventilation Equipment Planning on page 65).

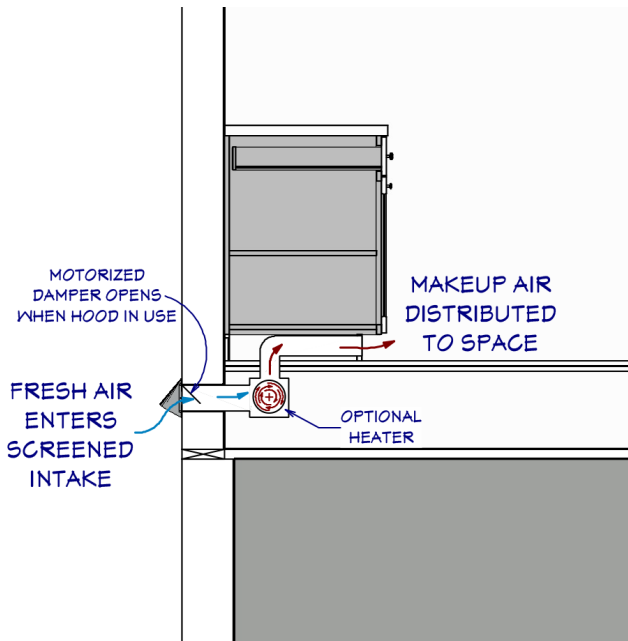

Figure 8.1.a Ventilation Planning

Bath Ventilation Planning

- A bath should have a minimum ventilation of 60 CFM (28 L/s). Baths with multiple fixtures (2 or more) may require additional ventilation.
- The location of ventilation fans may have special considerations for bathrooms with multiple fixtures. The following additional considerations affect ventilation planning and placement in a bathroom:
 - Toilet compartments should have a separate ventilation fan and wall switch/controls. Ventilation equipment may be a ceiling-mount or a wall-mount (verify your jurisdictional requirements.)
 - Showers with multiple heads and/or Wetrooms should have a separate ventilation equipment within the partitioned space that is ceiling-mounted with separate wall switch/controls. Higher air exchanges may be required.
 - Steam showers should have a separate ventilation equipment that is ceiling-mounted and planned within proximity of the operable transom with separate wall switch/controls.
 - Jetted tubs should have a separate ventilation equipment that is ceiling-mounted directly above the fixture with separate wall switch/controls.
- Wall switch/control locations should be planned between 36" (915 mm) and 48" (1 220 mm) AFF and near the entry/exit to the room.
- Manual ventilation controls should be supplied with timer settings between 0 to 60 minutes, operable with minimal effort, and easy to read. Controls that are motion-sensor activated or humidistat type will increase the ease-of-use by a variety of users.
- Ventilation fans with less than 1.0 to 1.5 sone ratings are quiet enough to be considered background noise.

- Natural ventilation (operable windows), when provided, should be no less than 4% of the total floor area being ventilated.

Laundry Room Ventilation Planning

- Clothes dryers should be connected to an independent rigid pipe exhaust system (vent) that terminates on the exterior of the home.
- The vent and lint trap should be accessible for periodic cleaning and maintenance to reduce the risk of fire.
- Additional proximity ventilation may be required depending on the number of fixtures and equipment located within the laundry room area.
- Condensation dryers require access to the inner reservoir to remove water and/or require a hose to drain directly into the clothes washer's standpipe.
- Refer to the manufacturer's installation manuals for all recommended ducting and electrical requirements.
- An HVAC professional should be consulted for specific venting and installation requirements and/or restrictions dictated by jurisdiction.

Utility & work spaces such as walk-in closets, home gyms and exercise areas may require additional ventilation such as an operable window, decorative ceiling fan, or other standard bathroom ventilation fans.

Indoor Air Quality

- To reduce fine particulate matter and improve indoor air quality, ventilation and portable air cleaners that have high efficiency particulate air (HEPA) or electrostatic precipitators may be utilized. The use of World Health Organization approved **in-duct** ultra-violet (UVC) equipment may be used to reduce exposure to mold, bacteria and/or viruses.

Ventilation terminating to the exterior should not be located within 36" (915 mm) of an operable window, door or indoor air intake. Minimizing the length of the duct run, as well as the number of elbows or bends, will increase the efficiency of the fan system. Air ducts that extract from the ventilated room may need to be insulated and should be appropriately sized according to the manufacturer recommendations with rigid ducting and exhausted through the roof, soffit or exterior wall in consultation with an HVAC professional.

8.2 Electrical Planning

Electrical receptacles (outlets) are required for all occupiable rooms. At least one (1) electrical receptacle should be planned at every activity center and in consideration of the user's height and reach at the point of use. In order to provide safe access for the user, avoid locating electrical receptacles directly behind a fixture or equipment and avoid installing an electrical receptacle in an exposed, uncovered horizontal position.

General Electrical Planning

- Receptacles should be planned in consideration of the user heights located between 18" (450 mm) and 48" (1 220 mm) AFF to the center line.
- Receptacles serving work surfaces should be spaced horizontally at a maximum 48" (1 220 mm) apart to avoid power cords of more than 24" (610 mm) in length.
- Receptacles planned within an enclosure or cabinet/ cabinet drawer may be subject to installation requirements and/or additional restrictions by jurisdiction.

Kitchen Electrical Planning

- One (1) receptacle should be planned on each side of a cooking surface and a sink.
- Islands and peninsulas wider than 48" (1 220 mm) should include a minimum of one (1) receptacle.
- GFCI (Ground fault circuit interrupter) protection should be provided at all locations serving work surfaces.

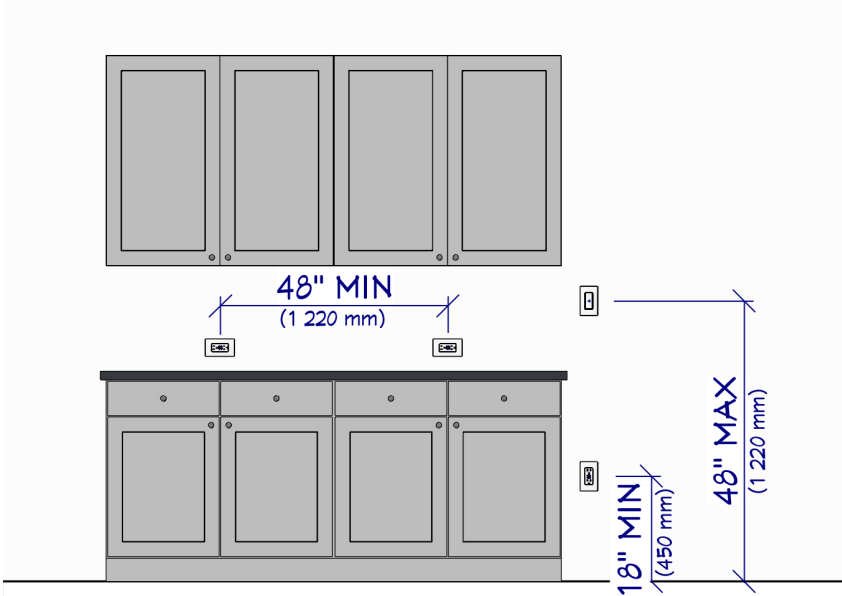

Figure 8.2.a Electrical Planning

Bath Electrical Planning

- GFCI (Ground Fault Circuit Interrupter) protection should be provided at all locations serving a bathroom and their fixtures (steam shower, jetted bathtub, radiant heat).
- Receptacles should be planned at a minimum distance of 39" (990 mm) away from any edge of a bathtub fixture or shower compartment.
- For toilets with integrated bidet features requiring power to operate the fixture, refer to the manufacturer's specifications for placement of the outlet.

Receptacles served by a GFCI breaker should be visibly marked at the service panel as GFCI-protected. The service panel should be located outside of the kitchen or bath area. Special use receptacles for appliances or other equipment requiring power, should have a dedicated branch circuit with a capacity as required by the equipment manufacturer and applicable building code.

8.3 Lighting Planning

An occupiable space should be illuminated with several layers of lighting and zoned by activity with a combination of general, task, and decorative lighting. Considerations when planning lighting layouts should include the space planned location within the home, the type of activity, the amount of illumination needed by the user, and the quality and type of light.

The following fixture types contribute the overall illumination:

Table 8.3.a	Illumination Types
General (Ambient)	Provides illumination for safe passage and circulation within the space.
Overhead Task	Planned directly above the surface to be illuminated, between the wall or cabinet above the work surface to the front edge of the work surface.
Wall-mounted Task	Planned from the user's eye-level height of the user, seated or standing.
Indirect	Includes under-cabinet lighting, toe-kick lighting, up-lighting or cove lighting in the ceiling. Under-cabinet lighting should be planned near the front edge of the cabinet or shelf for maximum illumination effectiveness.
Decorative	Planned in consideration of the user's height at a standing or seated position to avoid conflict with shadows. Decorative lighting uses a lower illumination output of lamp(s), additional task or downlighting may be needed to adequately illuminate an activity center. Also qualifies as general lighting.
Accent	Accomplished with a variety of lighting fixture types to highlight a focal point. Accent lighting can create the effect of wall-washing, grazing or spot-light illumination.

General Illumination Planning

- Task illumination at activity centers should provide a minimum of 50 fc (538 lux) depending on the visual needs and preferences of the user and the activity being performed.
- General illumination throughout the room or the space should provide a minimum of 20 fc (215 lux)
- Provide a minimum of 90 CRI for all illumination within a room or space for accurate color rendering.
- Color temperature ranges from 2700K to 5000K and should be determined by the users preference and the materials selected.
- Color temperature between illumination sources should be consistent within a room or space.
- Lighting fixture placement should consider effectiveness and the user's visual perception, and avoid direct or reflected glare from illumination sources and veiling reflections from polished surfaces.

Lighting Controls and Switching

- Wall switch/control locations should be planned between 36" (915 mm) and 48" (1 220 mm) AFF and near the entry/exit to the room.
- All lighting fixtures should be controlled by a dimming device or occupancy sensor.
- All light fixtures should be zoned to the activity center and switched appropriately to the entry and exits from the room or space.

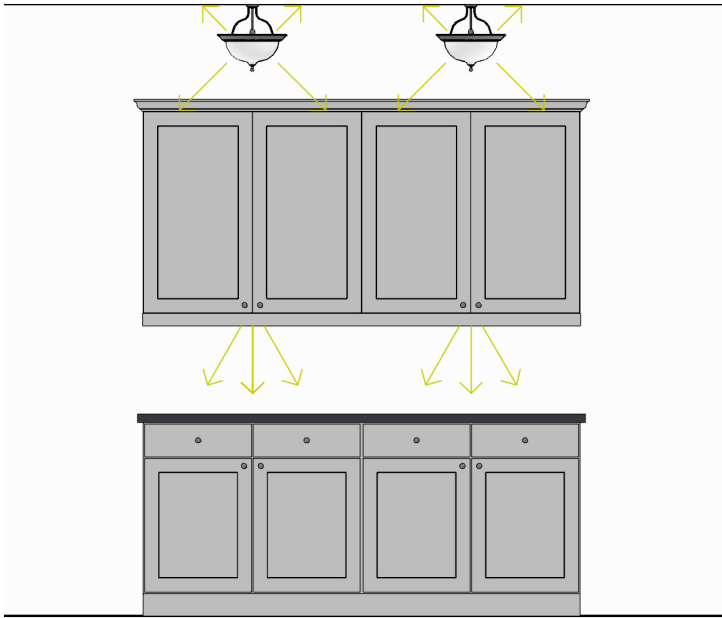

Figure 8.3.a Lighting Planning

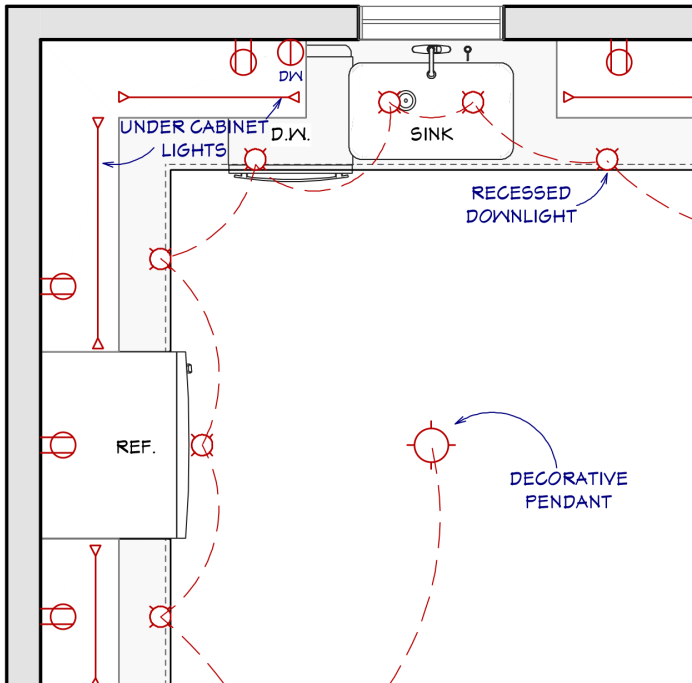

Figure 8.3.b Lighting Planning

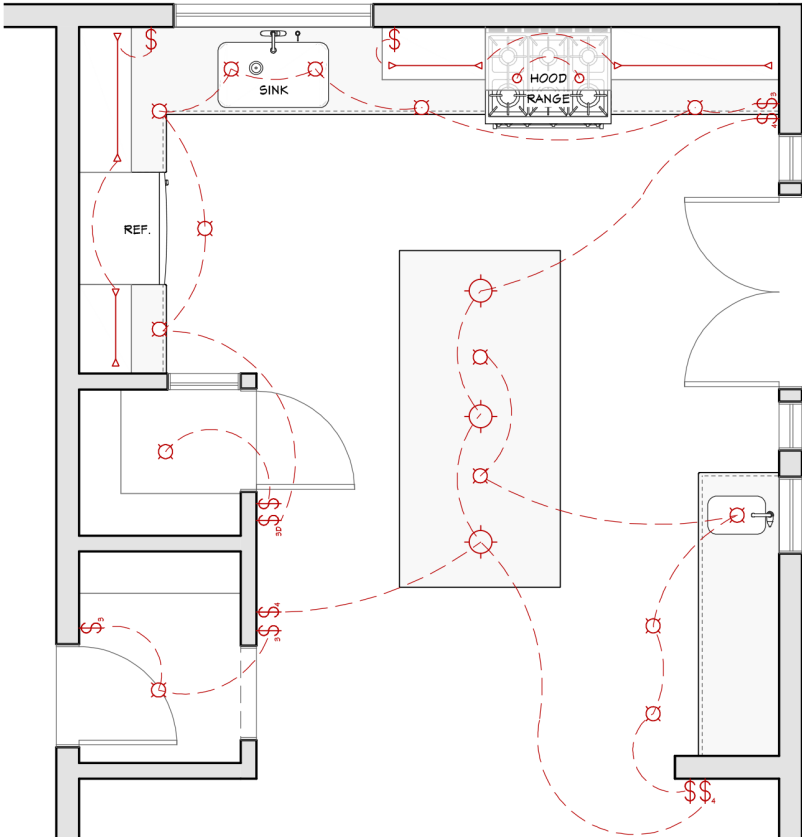

Figure 8.3.c Lighting Planning

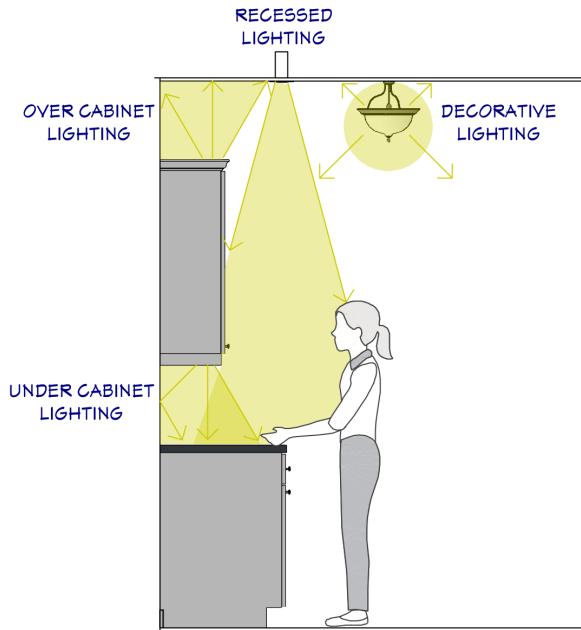

Figure 8.3.d Lighting Planning

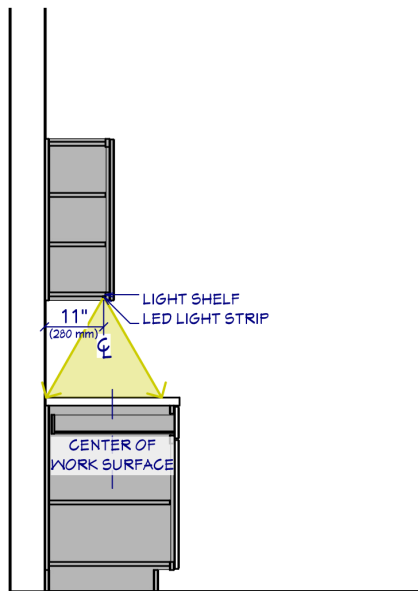

Figure 8.3.e Lighting Planning

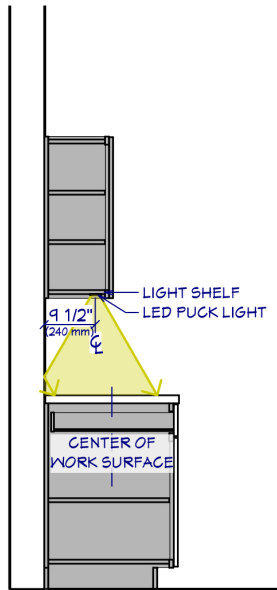

Figure 8.3.f Lighting Planning

Lighting Planning at the Grooming & Sink Center

There are two primary tasks that require illumination at the Grooming and Sink Center: the work zone and the user's face.

- For wall-mounted bath bar lighting over a mirror, for a standing user, plan the lighting fixture between 78" (1 980 mm) and 84" (2 135 mm) AFF with a clearance height of 6" (150 mm) above the fixture to the ceiling. For a seated user, plan the lighting fixture between 52" (1 320 mm) and 66" (1 675 mm) AFF. Bar light fixtures should not interfere with the safe operation of a surface or recessed medicine cabinet below the fixture.
- For wall sconces located to each side of a mirror or mounted directly to a mirror, plan the lighting fixtures at +/-60" (1 525 mm) AFF and adjusted as required to the user's eye level.

- For mirrors with integrated illumination, provide a dimmable fixture that will not interfere with the function of faucets and/or other fixtures and accessories. Fixture should deliver a minimum 50 fc (538 lux) to the user's face.
- For recessed lighting planned over the sink, provide illumination that is aligned with the center of the fixture and is directly over the work zone.
- For ceiling mounted pendant fixtures, plan the lighting fixture as required for the users eye level. The pendant location should not interfere with the function of faucets and/or other fixtures and accessories.

Lighting Planning at the Toileting Center

- Provide a recessed or ceiling mounted light fixture aligned above the front edge of the toilet seat.
- Safety (night) fixtures with a low-level of illumination should have a hard-wire installation, planned below eye-level and controlled by a motion activated sensor.

Lighting Planning at the Bathing & Showering Center

- Light switches/controls should be planned at a minimum distance of 39" (990 mm) away from any edge of a bathtub fixture or shower compartment.
- Decorative and surface-mounted lighting fixtures (wall-sconce, pendant, chandeliers, ceiling-mount, track, paddle fans) should not be installed within 36" (915 mm) horizontal from the edge of a bathtub fixture and 96" (2 440 mm) vertically above the bathtub fixture rim.
- Decorative and surface-mounted lighting fixtures should not be installed in any shower compartment.
- Lighting installed above a bathtub fixture or within a shower compartment should be appropriately rated for damp locations.

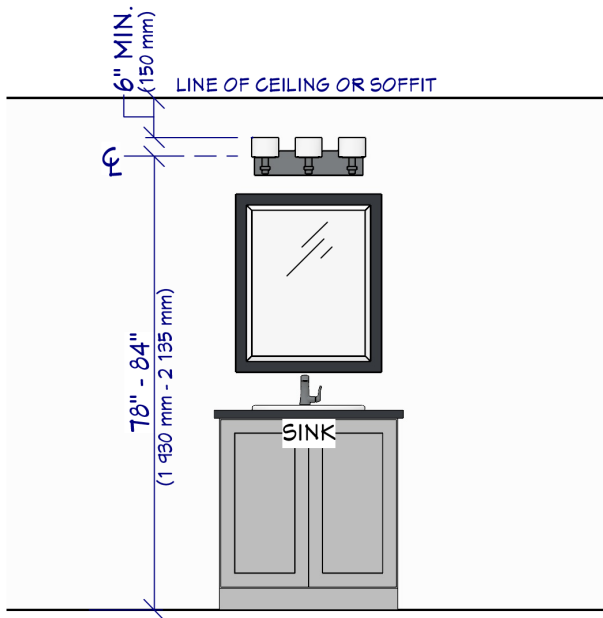

Figure 8.3.g Lighting Planning

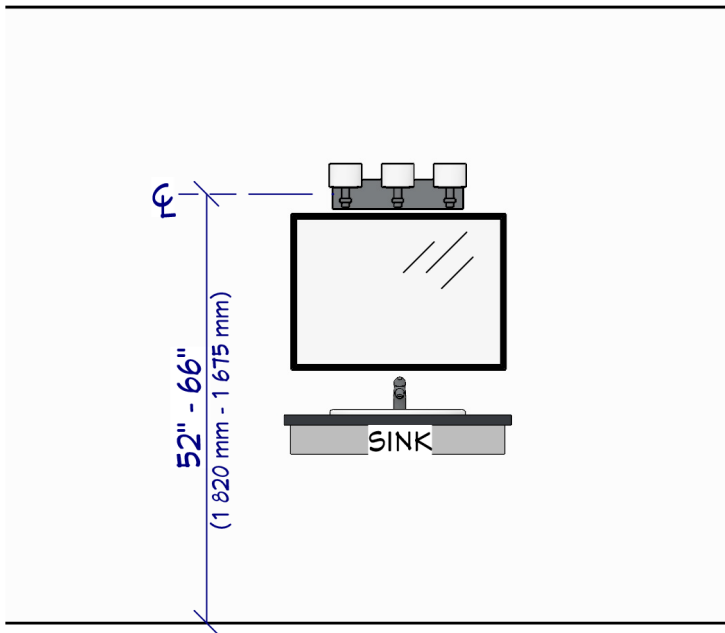

Figure 8.3.h Lighting Planning

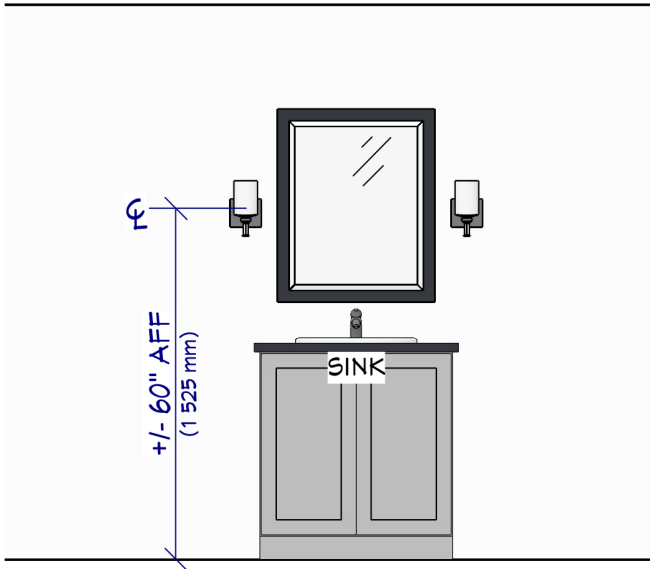

Figure 8.3.i Lighting Planning

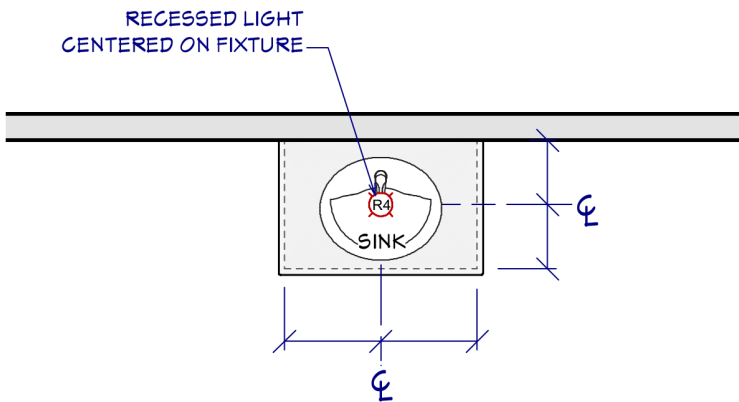

Figure 8.3.j Lighting Planning

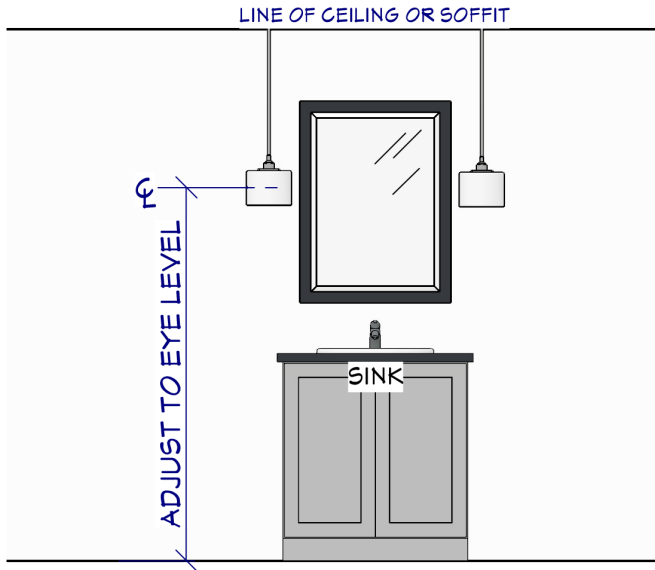

Figure 8.3.k Lighting Planning

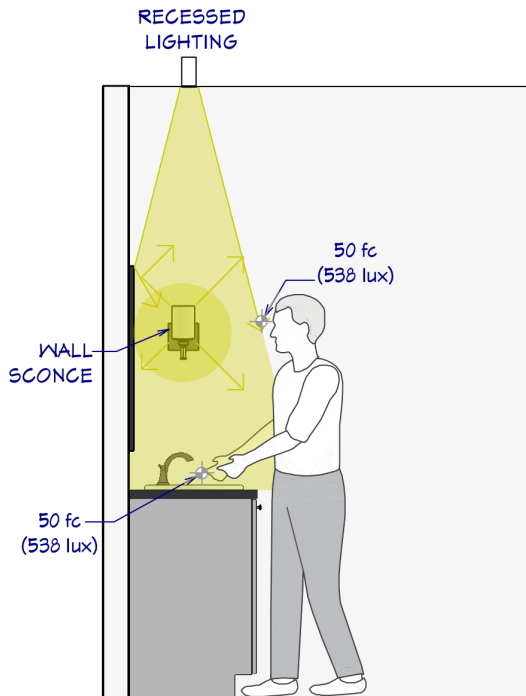

Figure 8.3.l Lighting Planning

THE ESSENTIAL KITCHEN AND BATH PLANNING REFERENCE, UPDATED TO REFLECT THE LATEST CODES AND ACCESSIBILITY STANDARDS ACROSS THE U.S. AND CANADA.

Kitchen & Bath Planning Guidelines

With Support Spaces and Accessibility

Fourth Edition

NKBA Kitchen & Bath Planning Guidelines With Support Spaces and Accessibility

provides the most complete collection of illustrations and planning recommendations available in one source for design professionals dedicated to the planning and installation of code-compliant and beautiful kitchens, baths, and more.

Developed by the National Kitchen & Bath Association, this fully revised Fourth Edition offers a highly visual reference tool for optimizing designs for functional and code-intensive kitchens, baths, laundry rooms, closets, home offices and gyms in a residential interior. Written, illustrated and prepared by a group of NKBA's foremost practicing Certified Master Kitchen & Bath Designers, Registered Architects, and Educators, this edition has been redeveloped to meet the increasing demands on design professionals while providing code-compliant, accessible, and beautiful interior spaces. With over 65 technical planning guidelines and 100 illustrations dealing with cabinet-centric residential interiors including assist bar locations, activity centers, indoor air quality, lighting and so much more, these guidelines are the foundational knowledge areas toward becoming an NKBA Certified Kitchen & Bath Designer (CKBD) and Certified Master Kitchen & Bath Designer (CMKBD) - the most coveted design certifications for professionals designing for residential interior environments.

NKBA | KBIS

The National Kitchen & Bath Association (NKBA) is a non-profit trade group that promotes professionalism in the kitchen and bath industry. Established in 1963 as a network of kitchen dealers, it has evolved into the premier association of designers, retailers, remodelers, manufacturers, distributors, fabricators, installers and other industry professionals. The association's vision is a world in which everyone enjoys safe, beautiful and functional kitchen and bath spaces. NKBA's mission is to help make it happen through the creation of marketplaces, networks, affiliations and certifications that raise the level of professionalism by inspiring, leading and empowering each member of our community.

